

ADC 6000 Series

AXI_e Digitizer Modules



- High-speed waveform digitizer with built-in processing hardware and fast data transfer to external computer
- Up to **13 GHz** analog bandwidth of 8-bit A/D Converter with **40 GSa/s** sampling rate in 1 channel mode
- **Up-to 128 GBytes** of acquisition memory per module. Total of **1.66 TByte** of acquisition memory available in 14 slot AXIe-1 chassis
- Digital hardware-accelerated frequency response equalization, with custom programming capability
- FPGA-based reconfigurable digital signal processing with up to **10 GSa/s** processing speed
- Multiple Firmware options available to accelerate measurements
- High-speed data transfer to host computer and graphic processors (GPU) for fast signal processing
- Up to **1.6 GByte/s** data transfer rate to computer using PCI Express x4 Gen 2 link
- 1U AXIe module 200 Watt maximum power consumption

Overview

Guzik AXIe ADC 6000 Series Digital Acquisition and Processing Modules combine high-speed waveform digitizer with built-in digital signal processing hardware, which enables mixed-domain signal capture and analysis with high-speed data transfer link to a computer. The ADC 6000 Modules come in a space-saving display-less 1U 19" AXIe modular form factor.

The product addresses demanding ATE and OEM systems applications in semiconductors, military electronics, physics, astronomy, avionics, and a variety of other disciplines, as well as the disk drive head and media testing applications.

The waveform digitizer ADC 6000 series modules feature Keysight A/D converters with sampling rates up to 40 GSa/s and analog bandwidth up to 13 GHz. ADC 6000 with up-to 128 GBytes of acquisition memory delivers the longest waveform capture time window available in a high bandwidth analog to digital converter instrument.

ADC 6000 features an FPGA-based reconfigurable digital signal processor with up to 10 GSa/s combined processing speed to convey massive time-critical computations directly inside the instrument.

The PCI Express Gen. 2 link provides fast DMA transfer of the acquired data to the host computer's GPU and CPU-based processing back-end. The x4 link delivers 1.6 GByte/s sustained data transfer rate.

A Software Development Kit is supplied to control the instrument and to integrate the ADC 6000 into an existing AXIe measurement system. Guzik also supplies Signal Display soft front panel graphical interface application for signal capturing and visualization.

The block diagram below shows the main components of ADC 6000 in an AXIe system in four-channel configuration:

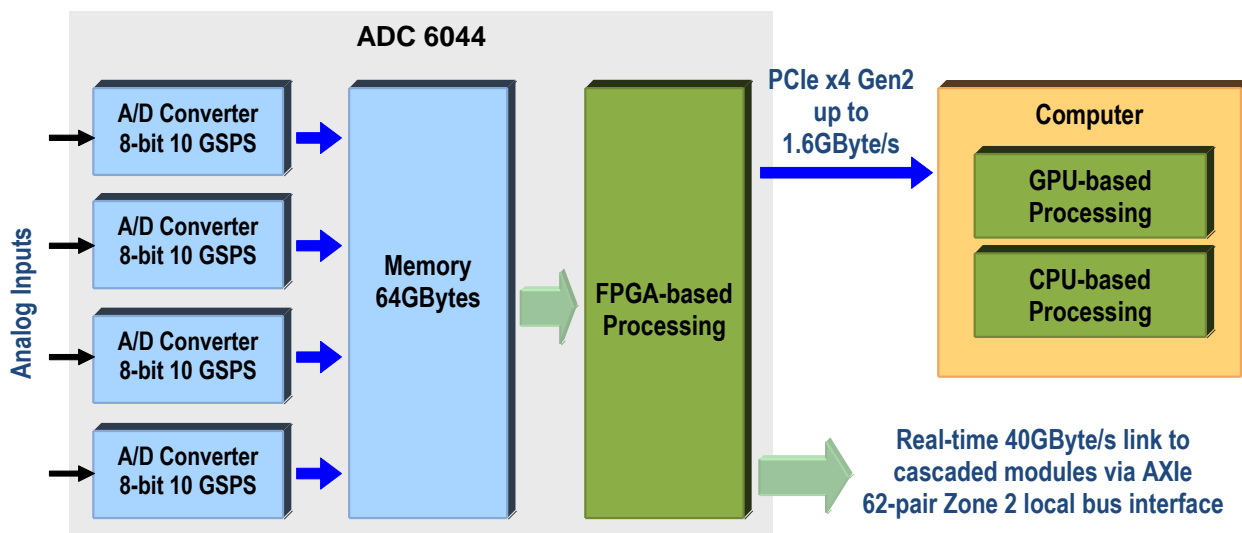

Figure 1. Block diagram of four-channel ADC 6000 in standard Keysight AXIe chassis

Guzik AXIe Digitizer Modules

ADC 6000 Series includes three modules listed in the table below:

	ADC 6131	ADC 6082	ADC 6044
Input Channels	1	2	4
Analog Bandwidth (-3db)	13 GHz	8 GHz	6.5 GHz (2-ch mode) 4 GHz (4-ch mode)
Sampling Rate (per channel)	40 GSa/s	20 GSa/s	20 GSa/s (2-ch mode) 10 GSa/s (4-ch mode)
Acquisition Memory (per channel maximum)	128 GBytes	64 GBytes	64 GBytes (2-ch mode) 32 GBytes (4-ch mode)
PCI Express Gen 2 Interface to computer	x4 standard	x4 standard	x4 standard

Acquisition System

At the heart of the ADC 6000 Digitizer Modules are state of the art high-speed real-time analog to digital converter ASICs supplied by Keysight Technologies, which provide high speed waveform capture. The patented¹ Guzik digital hardware-accelerated frequency response equalization further improves the signal fidelity and effective number of bits.

At the maximum sampling rate of 40 GSa/s (25 psec per point), the ADC 6000 can capture up to 3.2 seconds of a real-time waveform into its ultra-long acquisition memory – 128 GBytes for single channel configuration.

¹ U.S. Patent 7,408,495

Trigger

The ADC 6000 features a digital processing trigger. This feature makes use of the real-time hardware waveform processing capability and allows you to define trigger parameters based on the actual digital waveform data. This trigger is available on any input channel. In addition one of two external trigger/gate source inputs is provided. Trigger conditions are set using the Signal Display software tool or from your application via SDK.

External Clock and I/O



The ADC 6000 features a 10 MHz input and 50MHz reference clock input. 50MHz reference clock output from the digitizer is available to allow precise time base synchronization with more than one digitizer, oscilloscope, RF instruments or logic analyzers. Optionally a 1GHz reference clock connection can be made available instead of the internal ADC clock, by configuring the SPARE connector on the front panel as an input.

Several test outputs are available for custom application support and system integration.

ADC 6000 provides a programmable calibrator output with a variety of test signals. You can connect this calibrator to any input channel and run an automatic calibration routine to ensure accurate operation of the instrument.

PCI Express Host Computer Interface



The ADC 6000 provides PCI Express Gen 2 x4 interface to the AXIe backplane. The PCI Express bridge card installs into the host computer, and a standard PCI Express x8 cable connects the AXIe chassis to the host computer. High speed waveform transfer with sustained data rates up to 1.6 GByte/sec is possible from this port back to the host computer.

Processing Overview and Capabilities

ADC 6000 provides various options for signal processing: FPGA, GPU, and CPU-based processing.

FPGA-based Processing

Inside the ADC 6000 are four Altera Stratix™ IV FPGA's. These core processing elements combined with Guzik's implementation of customer-specified measurement algorithms provide end users with a truly tailored measurement solution where speed and throughput count.



The FPGA-based processor combined with Guzik's custom engineering capabilities provides you with the possibility to perform digital signal processing directly in ADC 6000 prior to sending waveform data out to computer. Many applications may require only processed results to be sent to the host computer rather than raw waveform data. Guzik can work directly with customers to implement custom processing capabilities drawing from years of experience in waveform analysis. Choice of firmware options includes channel equalization, filtering, multi-segment acquisition, Digital Down Conversion (DDC), Fast Fourier Transform (FFT), Discrete Fourier Transform (DFT), min/max, real-time averaging, and parameter calculations among others are all available along with application-specific requests. Guzik can provide custom services after a technical consultation regarding the specific application and required processing.

The combined FPGA processing resources are listed in the table below:

Processing Block	Number	Notes
Logic Cells	729,600	1 LUT and 1 flip-flop
Block RAM	4,940	9-Kbit blocks
	88	144-Kbit blocks
Multipliers	5,152	18-bit x 18-bit multipliers

Information about the ADC 6000 available firmware options:

Firmware Option	Description
ADC_BASE	Base license for acquisition and patented ² digital hardware-accelerated frequency response equalization, included with the digitizer.
ADC_BB	If bandwidth of signal is smaller than the digitizer bandwidth, the Baseband BB digital filtering and decimation is used to increase ENOB and reduce data amount needed to be transferred to the PC for post processing.
ADC_SM	Multi segment acquisitions in the Guzik digitizers use a circular acquisition buffer with minimum inter-segment dead-time of 300ns. This allows, for example, to capture repetitive signals with relatively large repetition intervals and better utilize the already large acquisition memory by discarding dead-time in between signals.
ADC_AVG	Averaging for noise reduction is used in measurements when high dynamic range is required. Averaging is done in real-time in FPGAs thousands of times faster compared to other methods. With the 40-bit 640K internal accumulator the accuracy of measurements is greatly increased by allowing up-to 4 billion averaged waveforms. This allows viewing side bands spectral regrowth and other repetitive signals previously hidden in the noise.
ADC_AVGS (Includes ADC_SM and ADC_AVG)	Segmented averaging mode further advances the measurement flexibility by utilizing groups of data of interest into segments. Each segment may either have its own trigger event programmed or just suspend the data accumulation process for specified period of time.
ADC_DDC	In Guzik digitizers the Digital Down Conversion DDC is realized using FPGAs. The data from ADC is transferred to the memory and from memory through digital equalizer to DDC. The down conversion is implemented by two multipliers with Sin/Cos LO signals. Down converted signals are connected through LPF/decimator to I/Q memory and transferred to PC. Keysight 89600 VSA software performs final processing and measurements related to particular transmission standard. This method significantly reduces the amount of data transferred to PC and in return increases measurement speeds.

GPU-based Processing



General-purpose computation on graphic hardware allows developers to reuse the computational algorithms available for GPU or develop their own algorithms on CUDA C or OpenCL. ADC 6000 is optionally shipped with NVIDIA[®] GeForce GTX 770³ GPU. It is possible to use any NVIDIA[®] GPU with computing capability 2.0 or higher, if its power requirements are satisfied by the host computer power supply.

² U.S. Patent 7,408,495

³ Current configuration. More powerful GPU cards may be shipped in the future

CPU-based Processing

In addition to FPGA-based and GPU-based computation, customers have an option to perform signal processing using a computer CPU. Multi-core processing libraries, such as OpenMP, allow utilizing full power of modern 12-core CPU computers. Once more powerful computers with additional cores are released, you can upgrade your computer keeping your existing ADC 6000 Digitizer Module.



Ultra-fast GPU-based FFT Measurements⁴

ADC 6000 performs frequency domain analysis using the Fast Fourier Transform (FFT) performed on GPU. Single NVIDIA[®] Tesla GPU card performs FFT calculations at a 2.5 GSa/s processing speed. This means, for example, that if you collect data at 10 GSa/s for 100 μ s, process in 400 μ s, you will get the full signal spectrum up to 5 GHz with resolution bandwidth 10 kHz – 500,000 spectral lines – in less than 0.5 ms.

Expandability

The ADC 6000 digitizer module features a real-time 40 GByte/s link through standard AXIe 62-pair Local Bus, which allows cascading multiple modules for increased memory, processing speed, and faster data streaming to computer. This is a special order configuration.

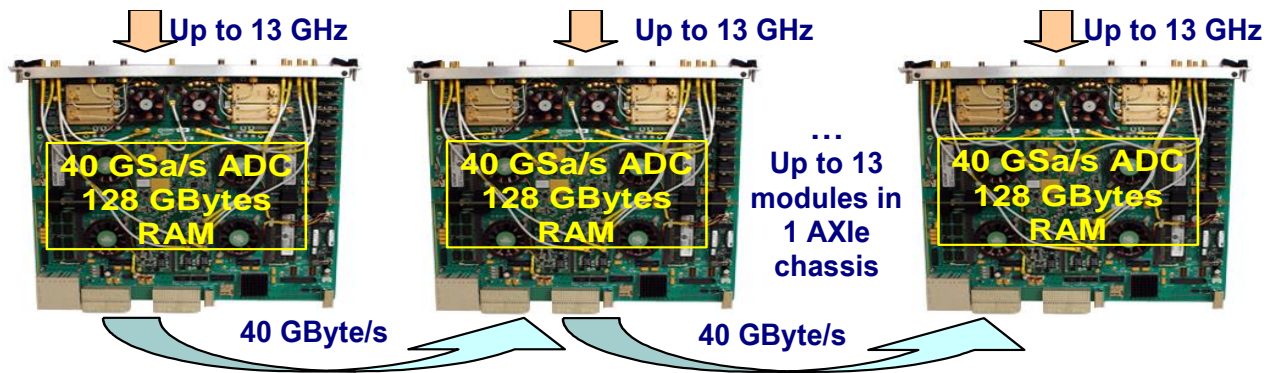

Up to 1.66 TBytes of memory is available for any channel in 14 slot AXIe chassis

Possible applications of the cascaded arrangement:

- Increased processing speed – acquire data by one board, transfer to and process by multiple boards, utilizing FPGA processors of several boards.
- Increased memory – acquire data by one board, transfer to multiple boards, utilizing memory of several boards. For example, combined memory of 13 boards is 1.66 TByte.
- Increased sampling rate – acquire data by two or more boards and interleave them.

⁴ Available using the GSA Software Development Kit (SDK)

Interleaving Modules

The ADC 6000 digitizer module's real-time 40 GByte/s link through standard AXIe 62-pair Local Bus allows two 13 GHz, 40 GSa/s ADC 6131 Modules to be interleaved to achieve 80 GSa/s sampling rate. The analog 13GHz signal should be Split and connected to the two individual inputs of the ADC 6131 Modules. This is a special order configuration.

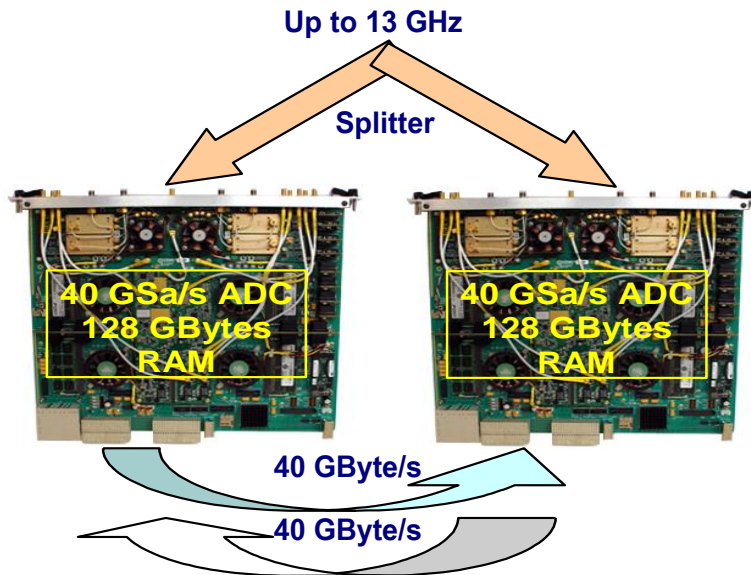

Temperature Stabilization

The ADC 6000 digitizer modules keep constant temperature for the critical A-to-D components for better measurement accuracy. Tested at ambient temperatures from 14 C to 34 C in Guzik GSA 6000 stand-alone chassis.

ADC 6000 Modules Designed for AXIe-1 Standard

The 1U AXIe ADC 6000 Digitizer Modules install into an industry standard AXIe-1 chassis together with other instruments, such as Keysight M8190A 12 GSa/s, M8195A 65GSa/s Arbitrary Waveform Generator, and other AXIe-0 or AXIe-1 modular instruments.



Signal Connection and Probing

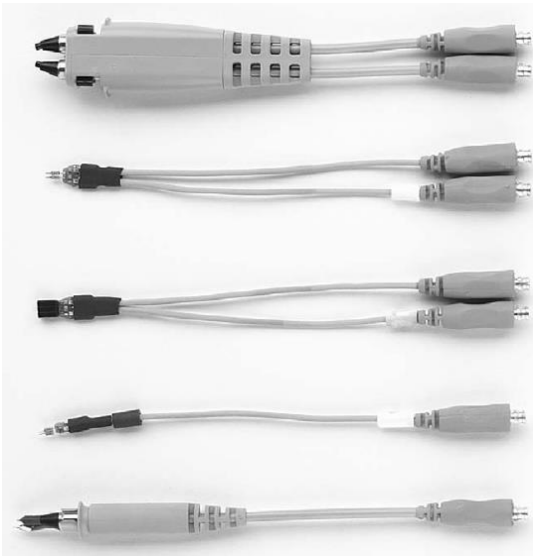

For applications that require single ended or differential probing, Guzik recommends the **Keysight InfiniiMax** series of probing tools for use with the ADC 6000 digitizer Modules. Detailed selection information can be found at the following link: <http://www.keysight.com/find/probes> document 5968-7141EN. A wide variety of probe solutions up to 13 GHz in bandwidth can be purchased directly from Keysight.

The Keysight InfiniiMax Series⁵ features a variety of probe amplifier and body styles.

The interface to the ADC 6000's input connector is the Keysight N1022A Probe Adapter with an additional cable adapter pictured below.

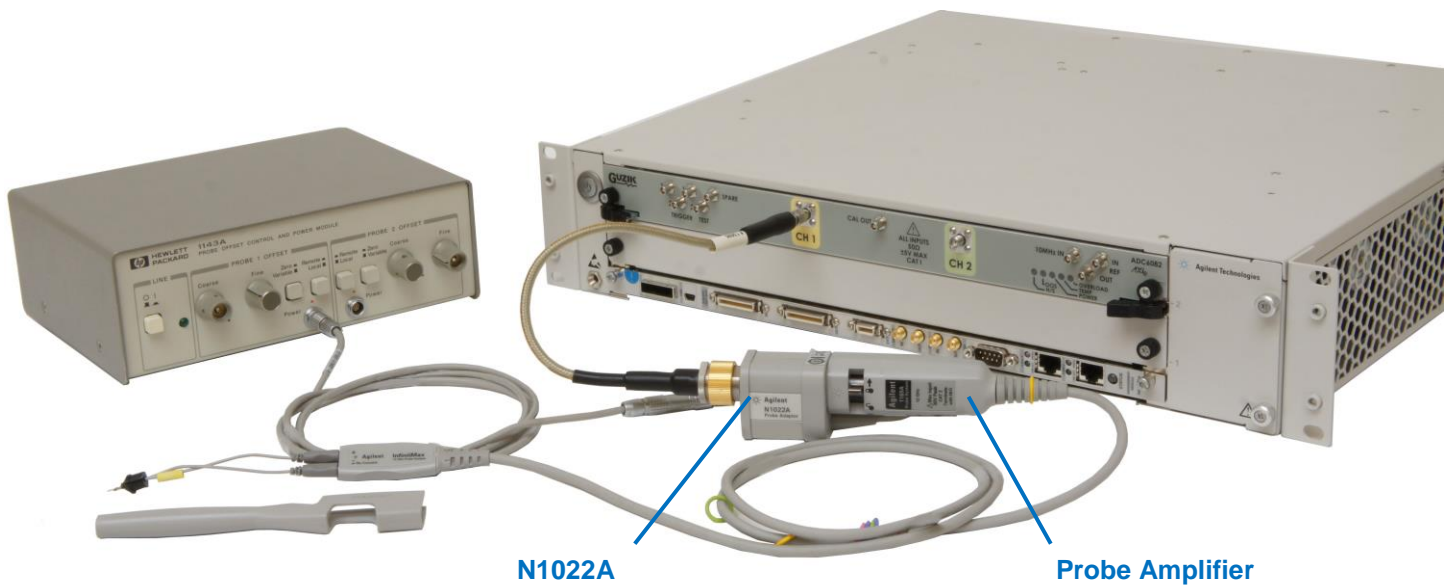

The ADC 6000 Modules feature 50 ohm SMA connectors for inputs and MCX connectors for trigger and control I/O connections.

⁵ Agilent and InfiniiMax are registered trademarks of Agilent, Inc.

GSA Toolkit Software

Guzik provides a GSA Toolkit to control the ADC 6000 Digitizer Modules, which includes two software components:

1. GSA SDK – software development kit to create your custom standalone applications for ADC 6000 or to integrate ADC 6000 into your existing software environment; please refer to “*Guzik Signal Analyzer Software Development Kit User’s Guide*” document P/N 02-107544 for more details.
2. Signal Display application designed for easy instrument setup, waveform acquisition and visualization. Signal Display provides oscilloscope-like graphical user interface to display multiple signal waveforms, frequency spectrum, control acquisition parameters (sampling rate, duration, trigger settings, etc), and perform multiple trigger (multi-sector) acquisitions. The application allows for saving acquired signals to files for importing into Keysight N8900A InfiniiView PC-based oscilloscope analysis software, Keysight 89600 VSA software, EXCEL, MATLAB or other computational and analysis programs. You can load and display signals from files in various formats, including the previously saved waveforms. One of the useful features of Signal Display is tracking (monitoring) acquired signals during GSA SDK-based application execution. Please refer to “*Signal Display User’s Guide*” document P/N 02-107548 for more details.

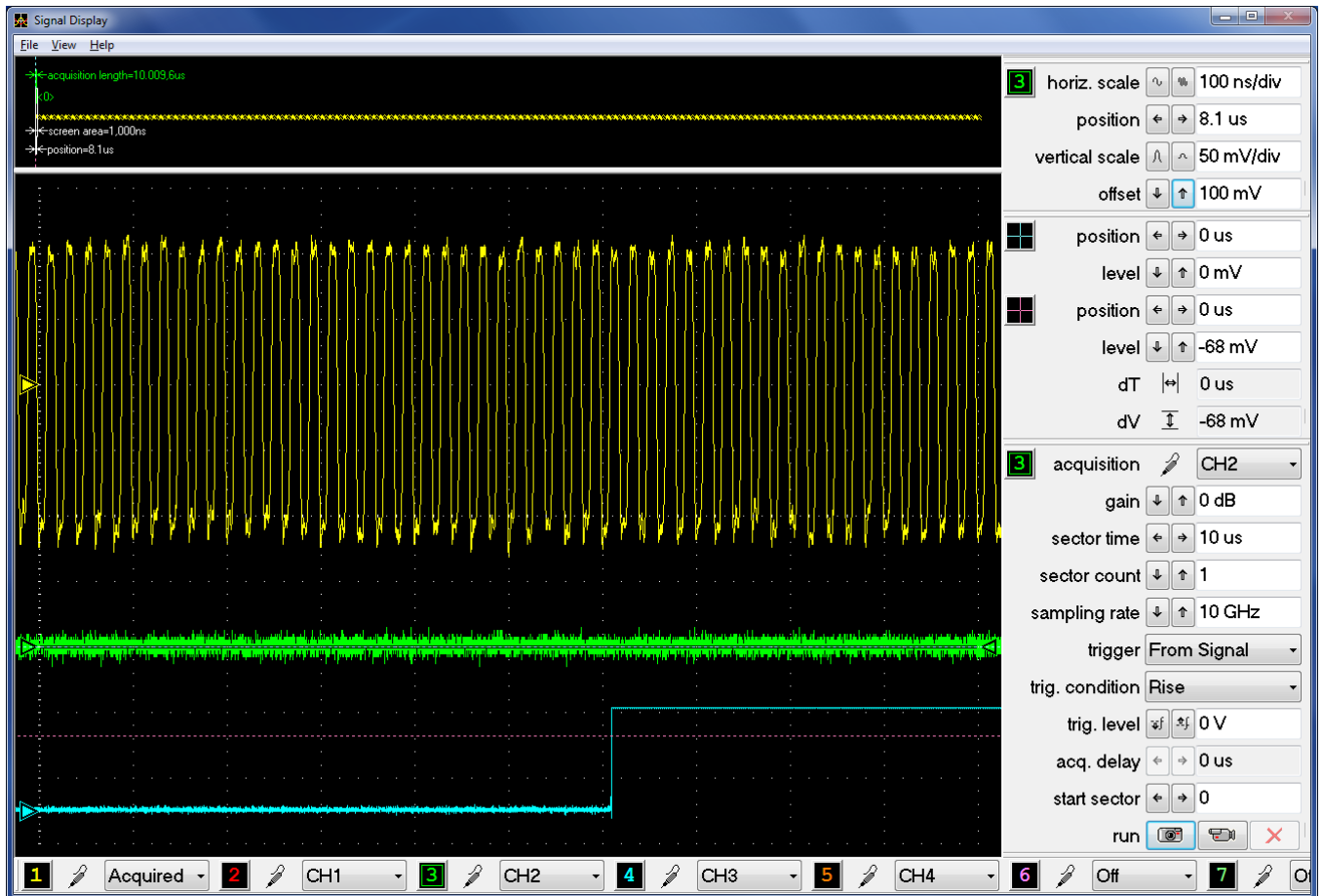

Figure 2. Signal Display Application

Specifications⁶

Vertical System ADC 6044		2 Channel Mode	4 Channel Mode
Input Channels		2, SMA Female	4, SMA Female
Analog Bandwidth (-3db) ^{1,2}		6.5 GHz	4 GHz
Vertical Resolution		8 bits	
Input Impedance		50 ohm ± 3%	
Input Coupling		DC	
Maximum Input Voltage		± 5 V	
Input Sensitivity		40 mV ... 8 V (Full Scale)	
Bandwidth Flatness ^{1,2} (-6 dBfs)		± 0.5 dB to 5 GHz -3 dB at 6.5 GHz	± 0.5 dB to 3.5 GHz -3 dB at 4 GHz
Effective Bits ¹ (-3 dBfs, 400 mV Full Scale)	<i>Frequency</i>		
	100 MHz	5.5	5.7
	1 GHz	5.4	5.7
	2 GHz	5.3	5.5
	3 GHz	4.7	5.5
	4 GHz	5.4	5.3
	6 GHz	5.2	–
Rise / Fall Time (10-90%)		68 ps	104 ps
RMS Noise Floor ¹	<i>Sensitivity (Full Scale)</i>		
	40 mV	410 uV	241 uV
	80 mV	723 uV	426 uV
	160 mV	1.35 mV	817 uV
	400 mV	2.56 mV	1.86 mV
	800 mV	4.54 mV	3.67 mV
	1.6 V	13.1 mV	8.32 mV
	4 V	24.3 mV	18.9 mV
8 V	45.5 mV	36.9 mV	

⁶ Specification values are typical. Specifications are subject to change.

Spurious Free Dynamic Range (SFDR)¹ (-3 dBFs, 400 mV Full Scale)	<i>Frequency</i>		
	100 MHz	44 dBc	45 dBc
	1 GHz	46 dBc	47 dBc
	2 GHz	40 dBc	47 dBc
	3 GHz	33 dBc	47 dBc
	4 GHz	52 dBc	47 dBc
	6 GHz	42 dBc	-

DC Gain Accuracy ± 2% of full scale at full resolution channel scale
(± 2.5% for 40 mV Full Scale)

Offset Range	<i>Vertical Sensitivity (Full Scale)</i>	<i>Available Vertical Offset</i>	
	0 ... 120 mV	± 0.30 V	
	> 120 ... 213 mV	± 0.50 V	
	> 213 ... 379 mV	± 0.95 V	
	> 379 ... 675 mV	± 1.70 V	
	> 675 ... 1200 mV	± 3.00 V	
	> 1200 mV	± 4.00 V	

Offset Accuracy Offset Range

TBD	TBD
-----	-----

Channel to Channel Isolation (any two channels with equal Vertical settings)	<i>Frequency</i>		
	< 2 GHz	55dB	55dB
	2 ... 4 GHz	55dB	45dB
	4 ... 6 GHz	36	

Return Loss < -12 dB to 4 GHz < -12 dB to 6 GHz

Acquisition System ADC 6044	2 Channel Mode	4 Channel Mode
Maximum Real Time Sample Rate	20 GSa/s	10 GSa/s
Memory Depth per Channel maximum	64 GBytes	32 GBytes
Maximum Acquired Time per Channel at Highest Real Time Sample Rate	3.2 seconds	

Vertical System ADC 6082**2 Channels**

Input Channels	2, SMA Female	
Analog Bandwidth (-3db) ^{1,2}	8 GHz	
Vertical Resolution	8 bits	
Input Impedance	50 ohm \pm 3%	
Input Coupling	DC	
Maximum Input Voltage	\pm 5 V	
Input Sensitivity	40 mV ... 8 V (<i>Full Scale</i>)	
Bandwidth Flatness ^{1,2} (-6 dBFs)	\pm 0.5 dB to 7 GHz -3 dB at 8 GHz	
Effective Bits ¹ (-3 dBFs, 400 mV Full Scale)	<i>Frequency</i>	
	100 MHz	6.0
	1 GHz	5.9
	2 GHz	5.7
	3 GHz	5.6
	4 GHz	5.5
	6 GHz	5.1
	8 GHz	4.8
Rise / Fall Time (10-90%)	49 ps	
RMS Noise Floor ¹	<i>Sensitivity (Full Scale)</i>	
	40 mV	315 μ V
	80 mV	400 μ V
	160 mV	580 μ V
	400 mV	1.60 mV
	800 mV	3.10 mV
	1.6 V	6.00 mV
	4 V	17.0 mV
	8 V	32.5 mV

Spurious Free Dynamic Range (SFDR) ¹ (-3 dBFs, 400 mV Full Scale)	<i>Frequency</i>	
	100 MHz	52 dBc
	1 GHz	52 dBc
	2 GHz	50 dBc
	3 GHz	52 dBc
	4 GHz	50 dBc
	6 GHz	45 dBc
	8 GHz	40 dBc
DC Gain Accuracy	± 2% of full scale at full resolution channel scale (± 2.5% for 40 mV Full Scale)	
Offset Range	<i>Vertical Sensitivity (Full Scale)</i>	
	<i>Available Vertical Offset</i>	
	0 ...358 mV	± 0.40 V
	> 358 ... 637 mV	± 0.70 V
	> 637 ...1133 mV	± 1.20 V
	> 1133 ... 2015 mV	± 2.20 V
> 2015 mV	± 4.00 V	
Offset Accuracy	Offset Range	
	TBD	TBD
Channel to Channel Isolation (any two channels with equal Vertical settings)	<i>Frequency</i>	
	< 8 GHz	48dB
Return Loss	< -14 dB to 8 GHz	

Acquisition System ADC 6082

Maximum Real Time Sample Rate	20 GSa/s
Memory Depth per Channel maximum	64 GBytes
Maximum Acquired Time per Channel at Highest Real Time Sample Rate	3.2 seconds

Vertical System ADC 6131**1 Channel**

Input Channels	1, SMA Female	
Analog Bandwidth (-3db) ^{1,2}	13 GHz	
Vertical Resolution	8 bits	
Input Impedance	50 ohm \pm 3%	
Input Coupling	DC	
Maximum Input Voltage	\pm 5 V	
Input Sensitivity	40 mV ... 8 V (<i>Full Scale</i>)	
Bandwidth Flatness ^{1,2} (-6 dBFs)	\pm 0.5 dB to 11 GHz -3 dB at 13 GHz	
Effective Bits ¹ (-3 dBFs, 400 mV Full Scale)	<i>Frequency</i>	
	100 MHz	5.6
	1 GHz	5.6
	2 GHz	5.5
	3 GHz	5.4
	4 GHz	5.2
	6 GHz	5.0
	8 GHz	4.6
	10 GHz	4.3
	13 GHz	4.2
Rise / Fall Time (10-90%)	32 ps	
RMS Noise Floor ¹	<i>Sensitivity (Full Scale)</i>	
	40 mV	485 μ V
	80 mV	550 μ V
	160 mV	670 μ V
	400 mV	2.10 mV
	800 mV	3.80 mV
	1.6 V	7.40 mV
	4 V	21.6 mV
	8 V	45.8 mV

Spurious Free Dynamic Range (SFDR) ¹ (-3 dBFs, 400 mV Full Scale)	<i>Frequency</i>	
	100 MHz	52 dBc
	1 GHz	52 dBc
	2 GHz	52 dBc
	3 GHz	48 dBc
	4 GHz	45 dBc
	6 GHz	45 dBc
	8 GHz	42 dBc
	10 GHz	38 dBc
	13 GHz	32 dBc
DC Gain Accuracy	± 2% of full scale at full resolution channel scale (± 2.5% for 40 mV Full Scale)	
Offset Range	<i>Vertical Sensitivity (Full Scale)</i>	
	<i>Available Vertical Offset</i>	
	0 ...358 mV	± 0.40 V
	> 358 ... 637 mV	± 0.70 V
	> 637 ...1133 mV	± 1.20 V
> 1133 ... 2015 mV	± 2.20 V	
> 2015 mV	± 4.00 V	
Offset Accuracy	Offset Range	
	TBD	TBD
Channel to Channel Isolation (any two channels with equal Vertical settings)	N/A	
Return Loss	< -12 dB to 12.5 GHz	

Acquisition System ADC6131

Maximum Real Time Sample Rate	40 GSa/s
Memory Depth per Channel maximum	128 GBytes
Maximum Acquired Time per Channel at Highest Real Time Sample Rate	3.2 seconds

Parametric Measurements Accuracy

TAA	$\pm 2\%$
Pulse Width / Rise / Fall Time	$\pm 3\%$ or 20 ps whichever is greater
SNR	± 0.5 dB
Crest Factor	$\pm 2\%$
Modulation	$\pm 2\%$
Overwrite	± 0.2 dB

Trigger

Trigger Types	Internal digital edge trigger on an input channel External edge trigger/gate resampled at 250 MHz												
External Trigger/Gate Input	2, MCX Female												
(TRIGGER 1, 2)	<table border="0"> <tr> <td>Impedance</td> <td>50 Ohm</td> </tr> <tr> <td>Voltage Range</td> <td>± 5V</td> </tr> <tr> <td>Trig. Level Range</td> <td>± 5V</td> </tr> <tr> <td>Threshold Resolution</td> <td>4 mV</td> </tr> <tr> <td>Max. Frequency</td> <td>100 MHz</td> </tr> <tr> <td>Hold-off time</td> <td>300 ns in post-trigger mode 1 micro-second in pre-trigger mode</td> </tr> </table>	Impedance	50 Ohm	Voltage Range	± 5 V	Trig. Level Range	± 5 V	Threshold Resolution	4 mV	Max. Frequency	100 MHz	Hold-off time	300 ns in post-trigger mode 1 micro-second in pre-trigger mode
Impedance	50 Ohm												
Voltage Range	± 5 V												
Trig. Level Range	± 5 V												
Threshold Resolution	4 mV												
Max. Frequency	100 MHz												
Hold-off time	300 ns in post-trigger mode 1 micro-second in pre-trigger mode												

Control Signal Connections

Calibrator Output	1, MCX Female								
(CAL OUT)	<table border="0"> <tr> <td>Impedance</td> <td>50 Ohm</td> </tr> </table>	Impedance	50 Ohm						
Impedance	50 Ohm								
External 10 MHz Reference Input	1, MCX Female								
(10 MHz IN)	<table border="0"> <tr> <td>Level</td> <td>0 to +10 dBm</td> </tr> <tr> <td>Impedance</td> <td>50 Ohm</td> </tr> <tr> <td>Coupling</td> <td>AC</td> </tr> <tr> <td>Stability</td> <td>+/- 10 ppm MAX</td> </tr> </table>	Level	0 to +10 dBm	Impedance	50 Ohm	Coupling	AC	Stability	+/- 10 ppm MAX
Level	0 to +10 dBm								
Impedance	50 Ohm								
Coupling	AC								
Stability	+/- 10 ppm MAX								

External 50 MHz Reference Input		1, MCX Female
(REF IN)	Level Impedance Coupling Stability	0 to +10 dBm 50 Ohm AC +/- 10 ppm MAX
External 50 MHz Reference Output		1, MCX Female
(REF OUT)	Level Impedance Coupling	800 mV p/p nominal 50 Ohm AC
External 1 GHz Clock Input		1, MCX Female
(Configured optionally instead of SPARE)	Level Impedance Coupling Stability	0 to +10 dBm 50 Ohm AC +/- 10 ppm MAX
Test Outputs		2, MCX Female
(TEST 1, 2)	Level	LV TTL
Spare		1, MCX Female
(SPARE)		

Host Computer

Transfer Interface	One PCI-Express x8 Generation 2 slot
Transfer Speed from PC to chassis	Up-to 3.2 GByte/s via PCI-Express x8 Generation 2 link from PC to AXIe-1 chassis.
Transfer Speed from chassis to module	Up-to 1.6 GByte/s via PCI-Express x4 Generation 2 link to AXIe-1 module.
Operating System	32-bit or 64-bit Windows 7 See Linux/Windows Hybrid Configuration in 02-107564 Appendix A.

Module Physical

Weight	5.1 lbs / 2.3 kg
Power	200 Watt Max
Operating Temperature Range	+5 C to +40 C
Non-Operating Temperature	-40 C to +70 C
Operating Altitude	Up to 4,000 meters (12,000 feet)
Non-Operating Altitude	Up to 15,300 meters (50,000 feet)

¹ With digital equalization

² 6-pole Butterworth approximation

Ordering and Availability

Hardware Base Modules:	P/N	Price	Typical Lead Time
ADC 6044, 64 GByte AXIe Digitizer Module with “basic” software	S90-620173-XX	Call	8-12 weeks
ADC 6082, 64 GByte AXIe Digitizer Module with “basic” software	S90-620185-XX	Call	8-12 weeks
ADC 6131, 64 GByte AXIe Digitizer Module with “basic” software	S90-620186-XX	Call	8-12 weeks
Firmware Options:			
ADC_BASE		Included with base module	
ADC_SM	S87-777623-XX	Call	Available
ADC_BB	S87-777624-XX	Call	Available
ADC-AVGS (Includes ADC_SM and ADC_AVG)	S87-777625-XX	Call	Available
ADC-AVG	S87-777618-XX	Call	Available
ADC_DDC	S87-777626-XX	Call	Available
Hardware Options:			
128 GByte memory option	TBA	Call	Available
Multi-module Configuration		Call	Call
Accessories:			
Guzik x8 PCIe Gen2 Bridge Card to connect AXIe chassis to the host PC	S60-705574-XX	Call	Available
x8 PCIe Gen2 Two Meter Cable Assembly	S30-109656-XX	Call	Available
Software Packages			
“Basic” software package includes:			
<ul style="list-style-type: none"> • GSA SDK APIs: Acquisition Sample code (C++, Matlab) • Signal Display Soft Front Panel 			



AXIe ADC 6131



AXIe ADC 6082



AXIe ADC 6044



20 channels of 10 GSa/s in the Keysight M9505A 5-slot chassis



2443 Wyandotte Street
Mountain View, CA 94043
Phone: (650) 625-8000
Fax: (650) 625-9325
E-mail: modularsales@guzik.com
<http://www.guzik.com/>
<http://www.twitter.com/GuzikTest>
<http://www.facebook.com/GuzikTest>